



SCANIA MÉXICO





Nuestro objetivo

Ser reconocidos como un verdadero aliado en la transformación hacia un transporte sustentable.

SCANIA



SUSTENTABILIDAD EN SCANIA

Transporte Sustentable

Hacer las cosas correctas

Contribuir a que la sociedad sea mejor desde un compromiso interno y externo, llevando a un fortalecimiento de nuestros negocios de largo plazo.

Liderazgo impulsado por el trabajo en equipo.

Negocio responsable

Hacer las cosas correctamente

Asegurar que nuestros actos sean responsables y con riesgos controlados, alineados con las expectativas en un camino que fortalezcan nuestra marca y nuestro negocio.



**NUESTRA MISIÓN ES QUE NUESTROS
CLIENTES ALCANCEN SUS OBJETIVOS
DE SUSTENTABILIDAD**

RED SCANIA EN MÉXICO

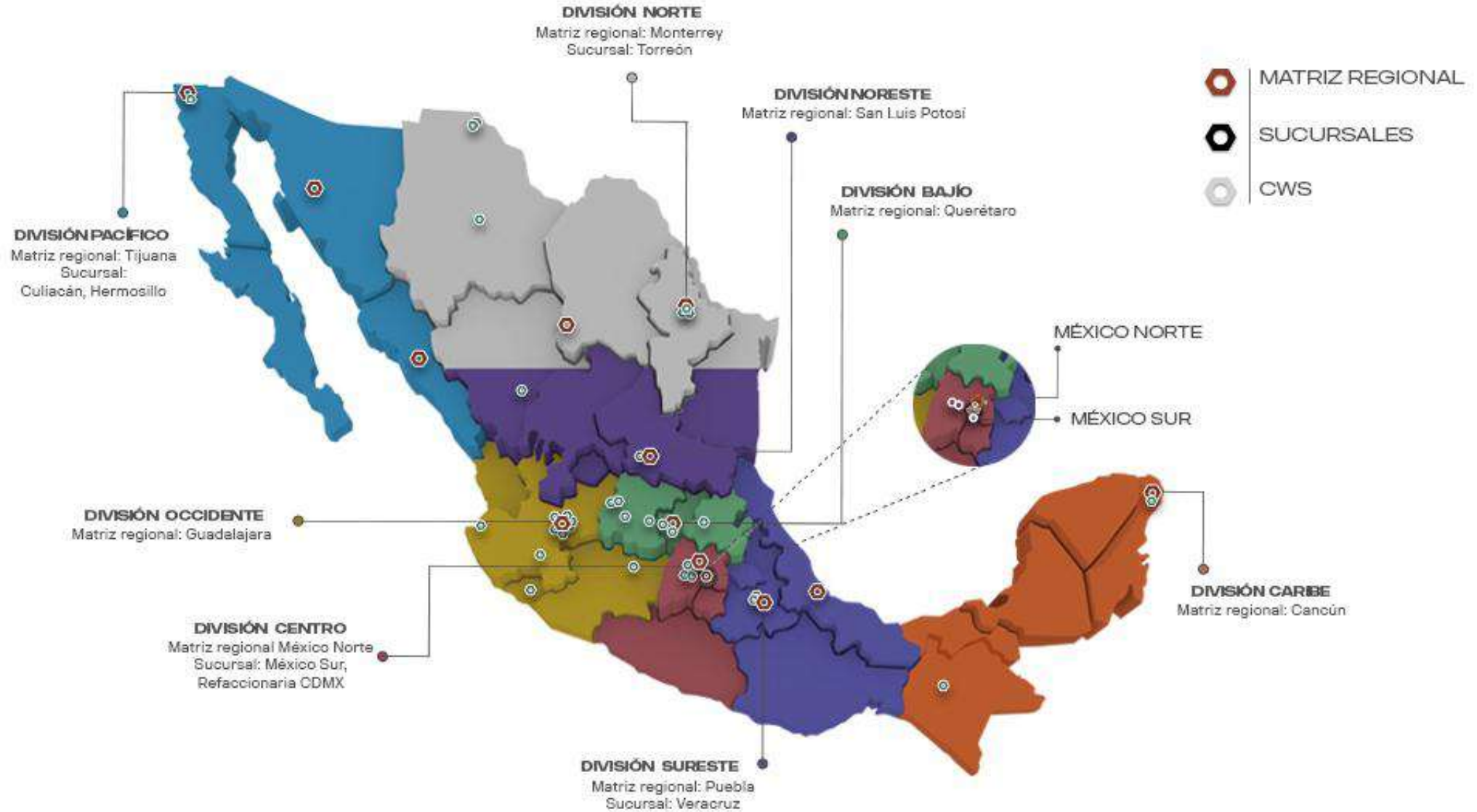

EL CAMINO DE SCANIA HACIA UN TRANSPORTE SUSTENTABLE



Eficiencia
Energética



Combustibles
Alternativos y
Electrificación



Transporte
inteligente y
seguro

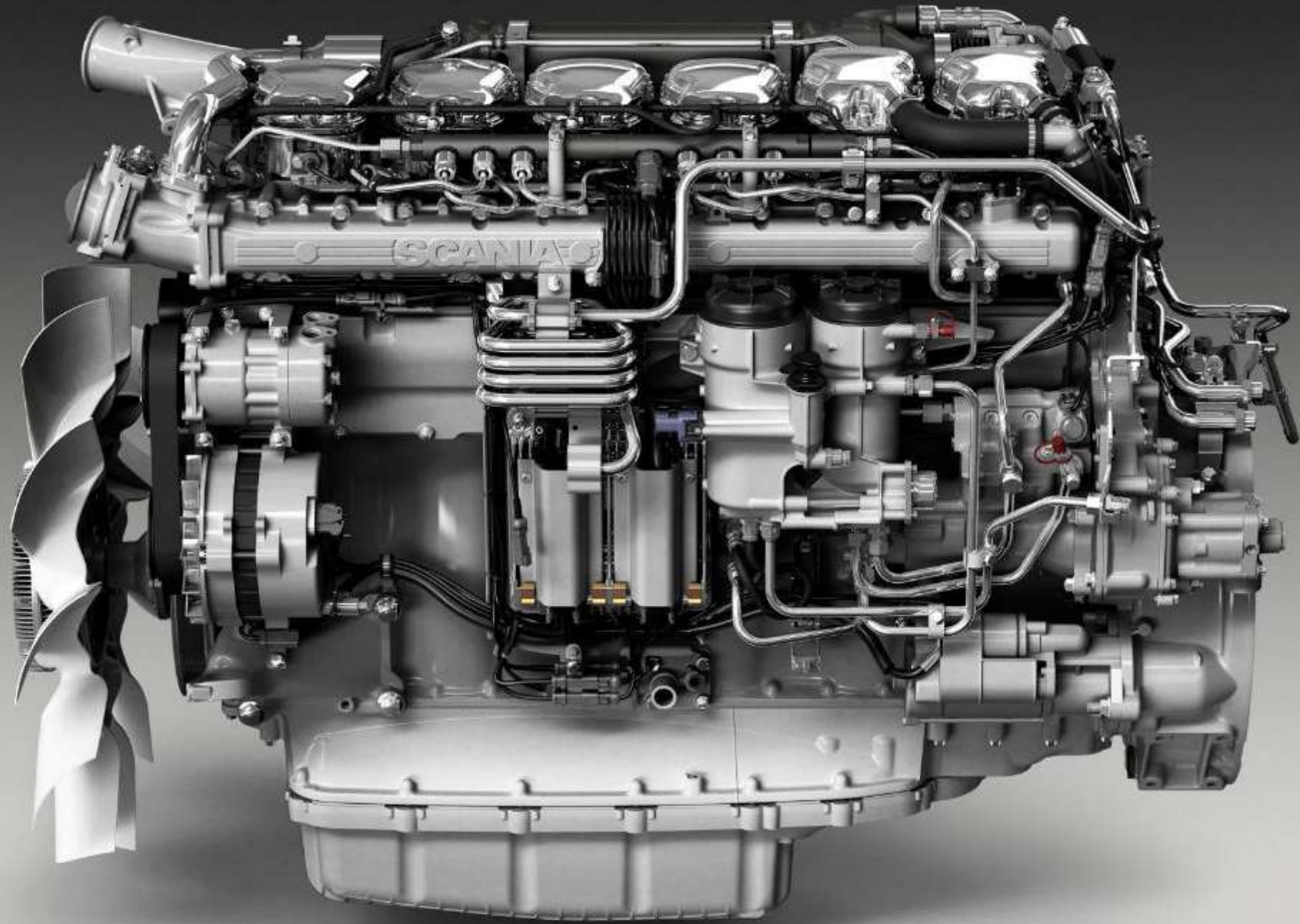

Eficiencia
Energética



TREN MOTRIZ SCANIA

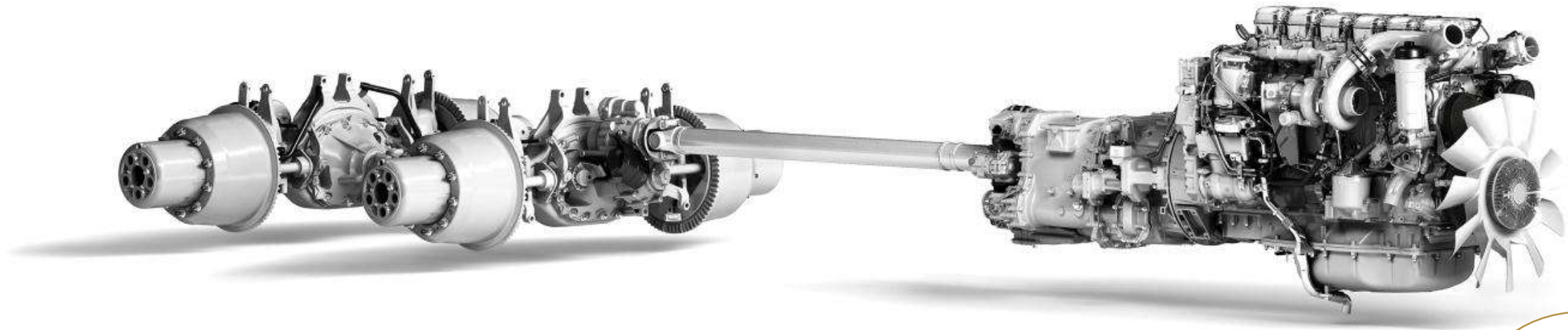

Eficiencia
Energética



REDUCCIÓN DE EMISIÓN DE CO2

GNC/GNL
-15%

Biogas
-90%

Hidrógeno
-90%

Biodiésel
-66%

Etanol
-90%



Combustibles
alternativos y
electrificación



SISTEMA MODULAR

CAMIONES Y AUTOBUSES

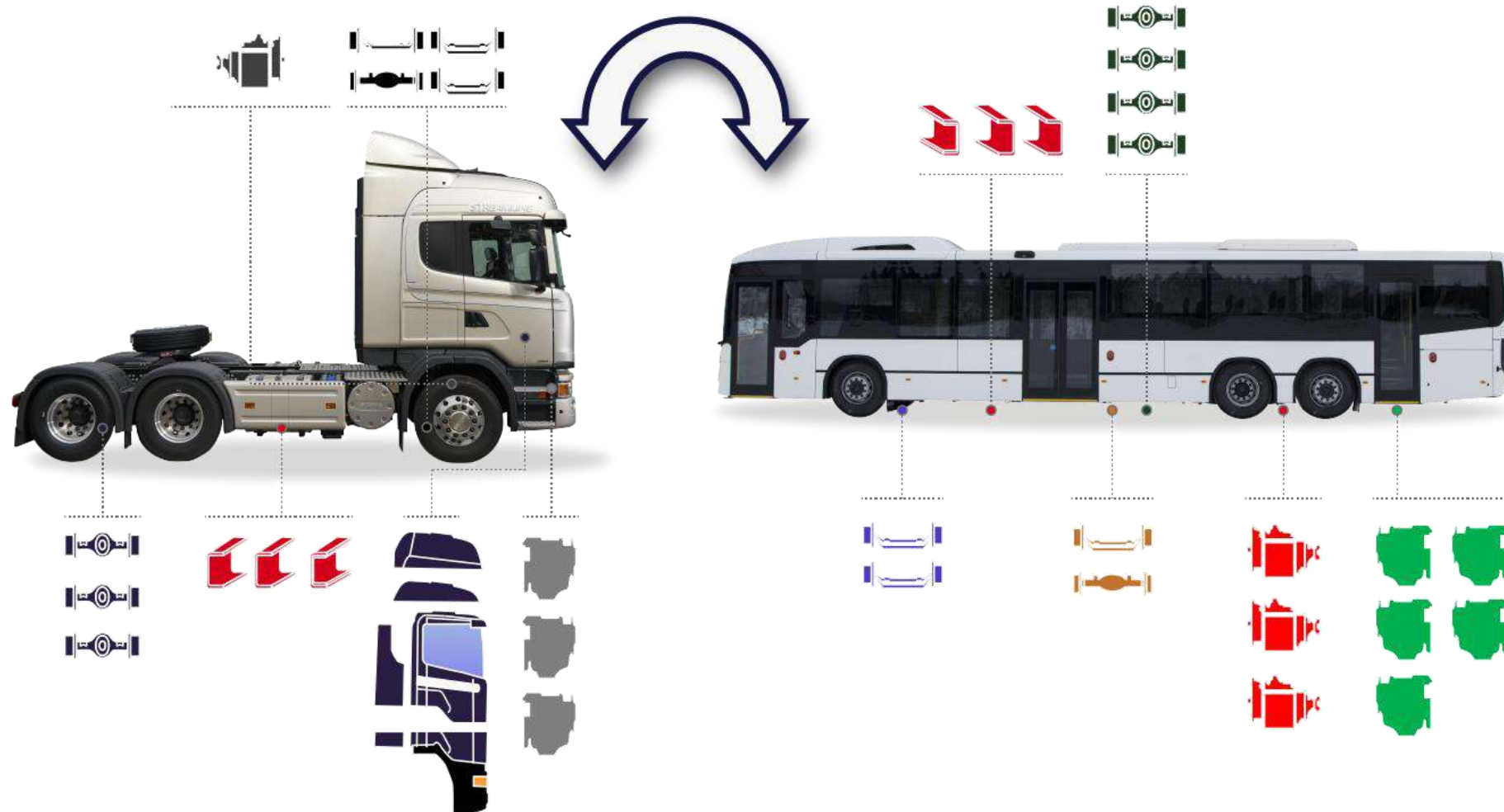

APLICACIONES AUTOBUSES



URBANOS



Sistemas BRT/BRS

INTERURBANOS



Transporte de personal
Suburbanos

FORÁNEOS



Ocasional
Turismo

PORTAFOLIO URBANO/ BRT

SCANIA

EXPERIENCIA EN SISTEMAS BRT EN MÉXICO



MEXIBUS, ESTADO DE MÉXICO



OPTIBUS, LEON



RUTA, PUEBLA



SITT, TIJUANA



EL SALTO, GUADALAJARA



METROBUS, CIUDAD DE MÉXICO

SCANIA



TECNOLOGÍA SCANIA EURO 6 GNC

SCANIA

EXPERIENCIA CON GAS DESDE 1929





¿POR QUÉ GAS?

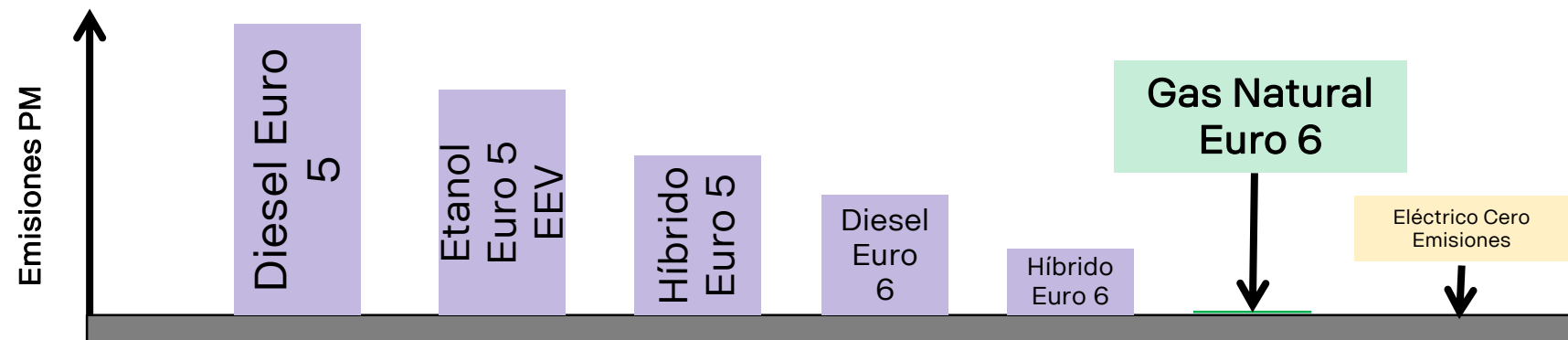
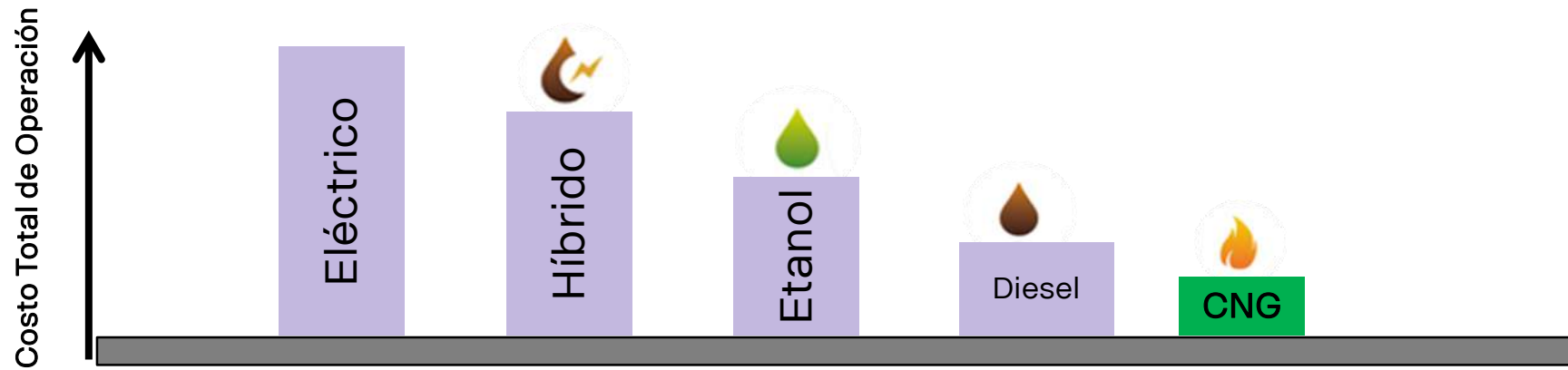

MOTORES SCANIA EURO 6 CNG





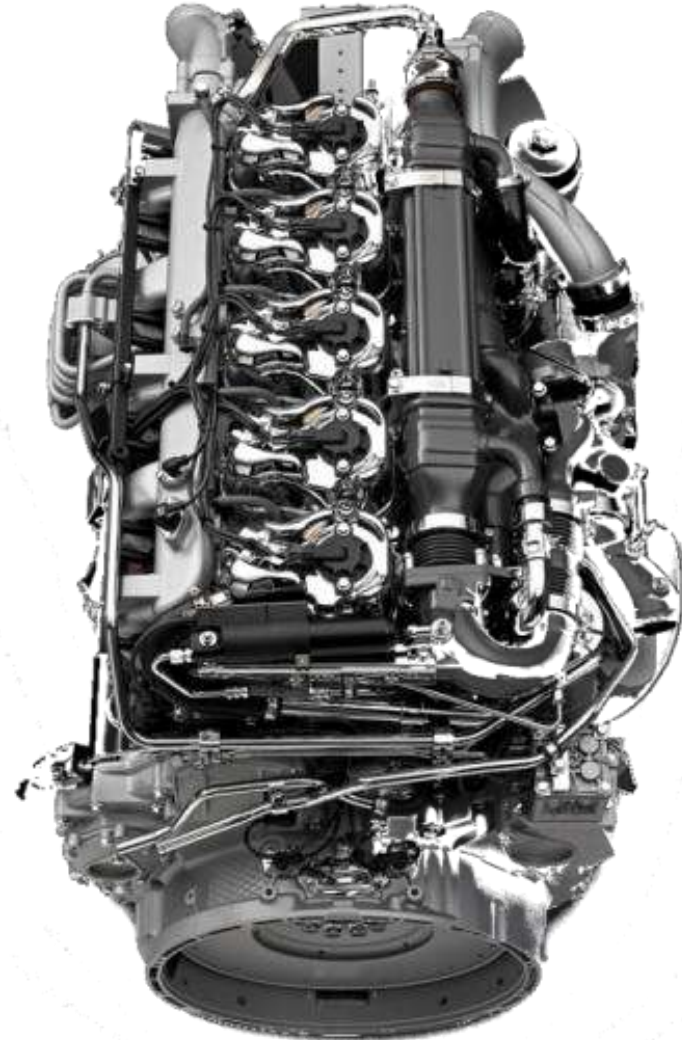



- Cumplen con la normativa Euro 6 de emisiones
- Reducción de 99% de PM10 comparado con un motor diésel Euro 5
- Preparado para operar hasta los 3000 m.s.n.m
- Emisiones sonoras 10 veces menores a las de un motor diésel
- Plataforma Modular
- Puede operar con Gas, Biogás o una mezcla de los dos

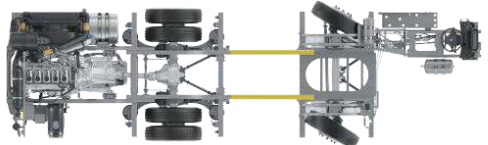

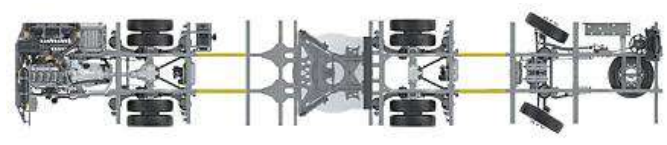
PORTAFOLIO SCANIA GNC



	4X2	6X2*4	6X2/2	
GNC				Entrada Baja Entrada Normal 280-320 hp
				



PRIMER ARTICULADO A GAS NATURAL EN MÉXICO



BI-ARTICULADO 28 METROS

CAPACIDAD APROX. 260 PASAJEROS



F340 8X2

GAS EURO 6





NIVEL DE EMISIONES SCANIA EURO 6

NOx y Material particulado - g/kWh

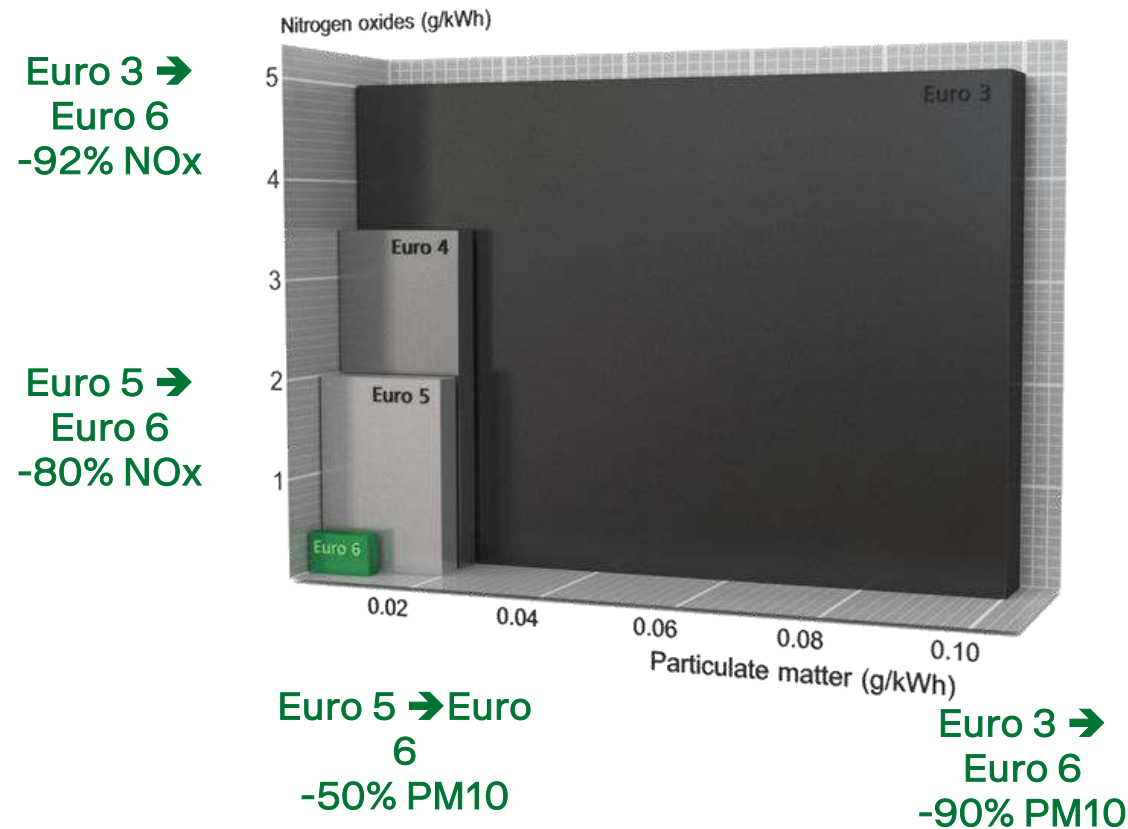

Emisión de PM

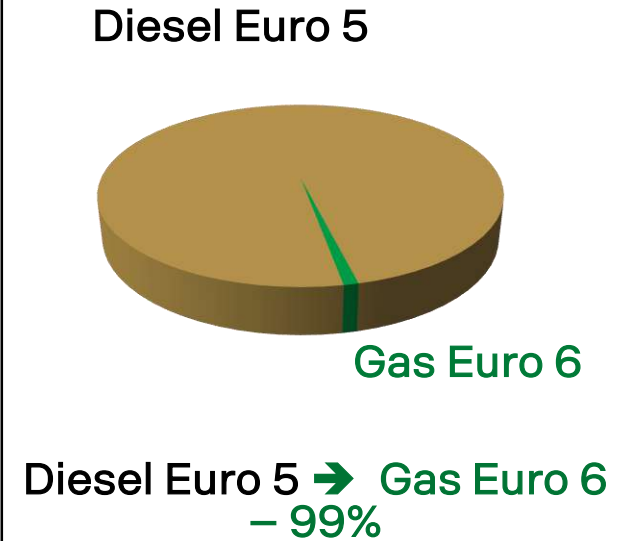

Euro 6 Diesel → NOx: 0.40 g/kWh | MP: 0.01 g/kWh



COMPORTAMIENTO DEL MOTOR

MOTOR	Altitud (m)	Revoluciones del motor (r/min)						Comentario
		600 (ralentí)	1000	1100	1500	1600	1900	
OC09 101 - 280 hp	4000							No recomendado
	3000	70	95	95	95	95	95	Recomendado
	2500	80	100	100	100	100	100	
	2000	80	100	100	100	100	100	
	1500	85	100	100	100	100	100	
	1250	88	100	100	100	100	100	
	1000	90	100	100	100	100	100	
	500	100	100	100	100	100	100	

MOTOR	Altitud (m)	Revoluciones del motor (r/min)						Comentario
		600 (ralentí)	1000	1100	1500	1600	1900	
OC09 106 - 320 hp	4000							No recomendado
	3000	70	90	90	90	90	90	Recomendado
	2500	80	95	95	95	95	95	
	2000	80	98	98	98	98	98	
	1500	85	100	100	100	100	100	
	1250	88	100	100	100	100	100	
	1000	90	100	100	100	100	100	
	500	100	100	100	100	100	100	



EXPERIENCIA EN SISTEMAS BRT A GNC EURO 6

TransCaribe. Cartagena, Colombia



TransJakarta. Jakarta, Indonesia



CONECTIVIDAD



Transporte
Inteligente
y seguro

SISTEMA DE GESTIÓN DE FLOTAS



DEMO Ventas Mexico

FMS México FM

Buscar equipo, conductor o dirección.

Mapa Vehículos Eventos Más

Todo el equipo

+170,000 VEHÍCULOS CONECTADOS EN EL MUNDO

+3,000 VEHÍCULOS CONECTADOS EN MÉXICO

FEEDBACK

AYUDA

Mensajes

© 1987-2017 HERE | Terms of use



COMPROMETIDOS CON EL MEDIO AMBIENTE

Rendimiento del vehículo

Resumen

Detalles

Comparar

Informe de emisiones

Informe de combustible

Configuración

INFORME DE EMISIONES

1/2/17 0:00 ↔ 28/2/17 23:59

Todos los grupos

febrero 2017

225.674 kg
CO₂
Dióxido de carbono

246.433 km
Distancia recorrida
51
Número de vehículos

786,88 kg
NOx
Óxido de nitrógeno

5,29 kg
PM
Partículas

12,99 kg
HC
Hidrocarburos

147,57 kg
CO
Monóxido de carbono

▼ EQUIPO	DISTANCIA (km)	CONSUMO DE COMBUSTIBLE	NOX (kg)	PM (kg)	HC (kg)	CO (kg)	CO ₂ (kg)	ESPECIFICACIÓN DE EMISIÓN
GP45 6377	23.895	6.702 l	73,0	0,40	0,94	11,7	18.093	Euro 4, SC, DC13 102 ⓘ
GP45 6372	23.712	6.626 l	72,2	0,40	0,93	11,6	17.888	Euro 4, SC, DC13 102 ⓘ
ECO 1173 Plata	16.454	4.316 l	47,0	0,26	0,60	7,6	11.653	Euro 4, SC, DC13 102 ⓘ
ECO 1172 Blanco	10.510	2.998 l	32,7	0,18	0,42	5,2	8.092	Euro 4, SC, DC13 102 ⓘ
ECO 1171 Mostaza	9.396	2.945 l	32,1	0,18	0,41	5,2	7.949	Euro 4, SC, DC13 102 ⓘ
ECO 1170 Amarillo	14.541	3.449 l	37,6	0,21	0,48	6,0	9.312	Euro 4, SC, DC13 102 ⓘ
ECO 1169 Azul	17.323	4.393 l	47,9	0,26	0,61	7,7	11.858	Euro 4, SC, DC13 102 ⓘ
ECO 1168 Rojo	14.645	3.876 l	21,5	0,23	0,50	6,2	10.463	Euro 5, SC, DC13 112 ⓘ

FEEDBACK

¿CÓMO FUNCIONA DRIVER COACHING?



ENTRENAMIENTO INICIAL



TRANSFERENCIA DE DATOS

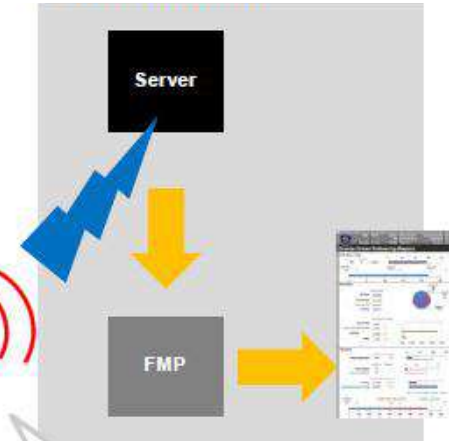

ANÁLISIS DE DATOS



RETROALIMENTACIÓN



Repeated every month



EL CONDUCTOR, GESTOR DE LA SUSTENTABILIDAD

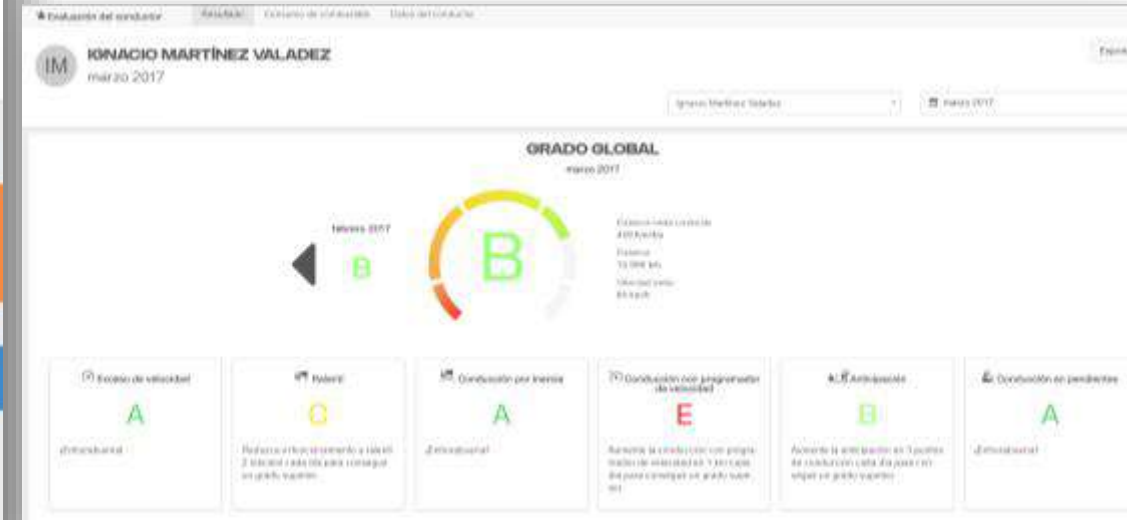
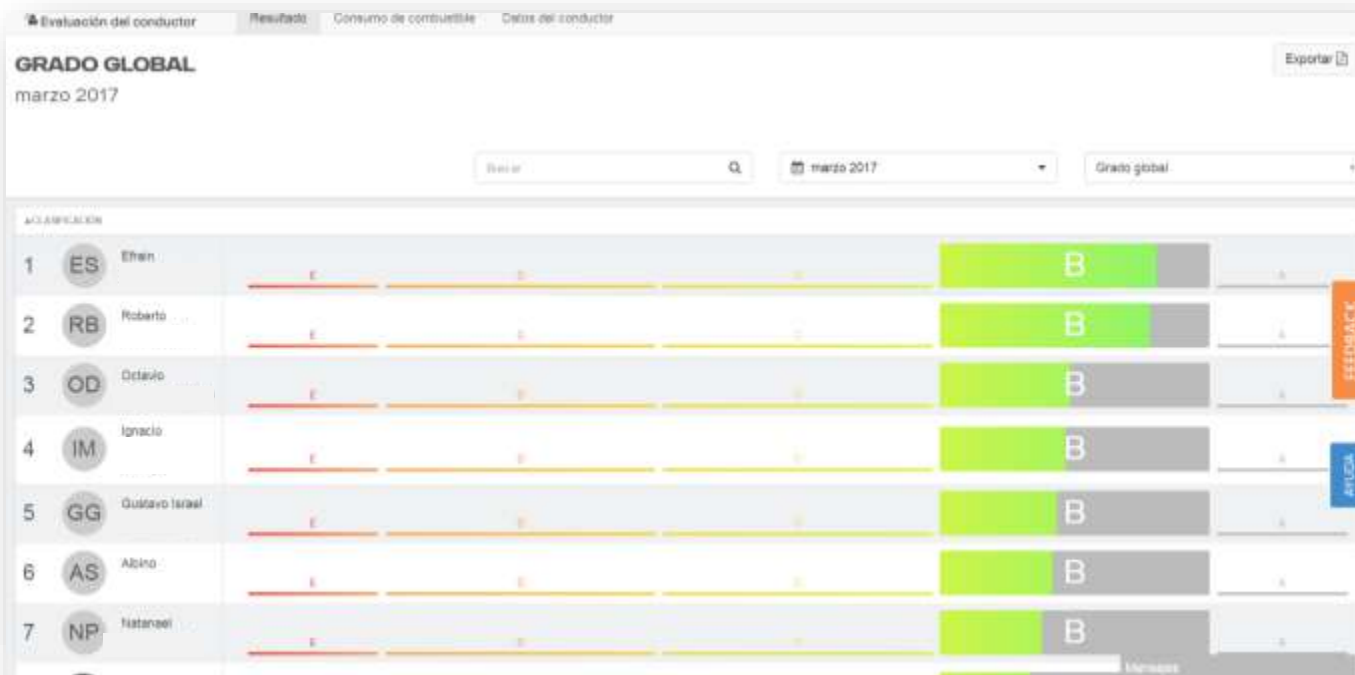



SCANIA DRIVER SUPPORT

- Retroalimentación en tiempo real
- Evalúa el manejo en cuestas, anticipación, uso de frenos y selección de velocidad
- Diseñado para mantener habilidades y motivar a los conductores.

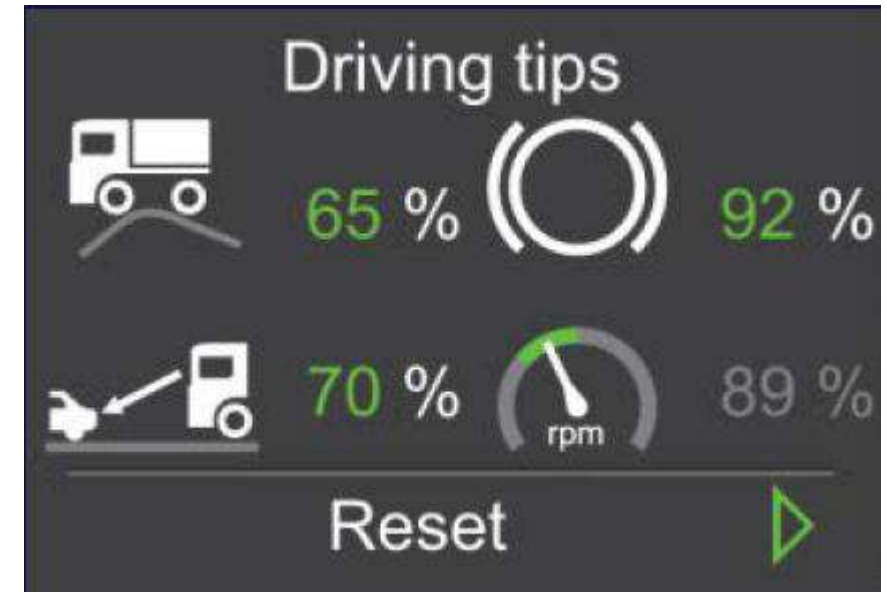



DRIVER COACHING

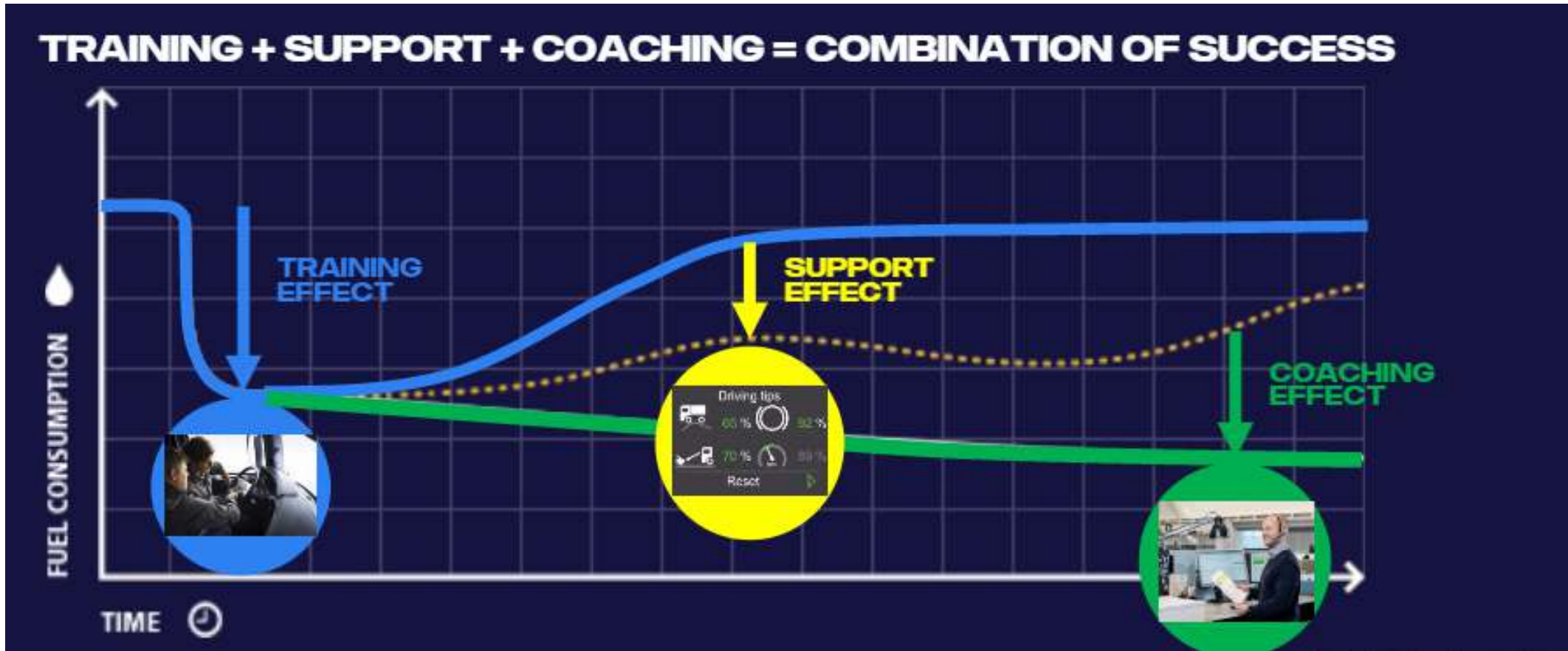

LA SUSTENTABILIDAD UNA REALIDAD

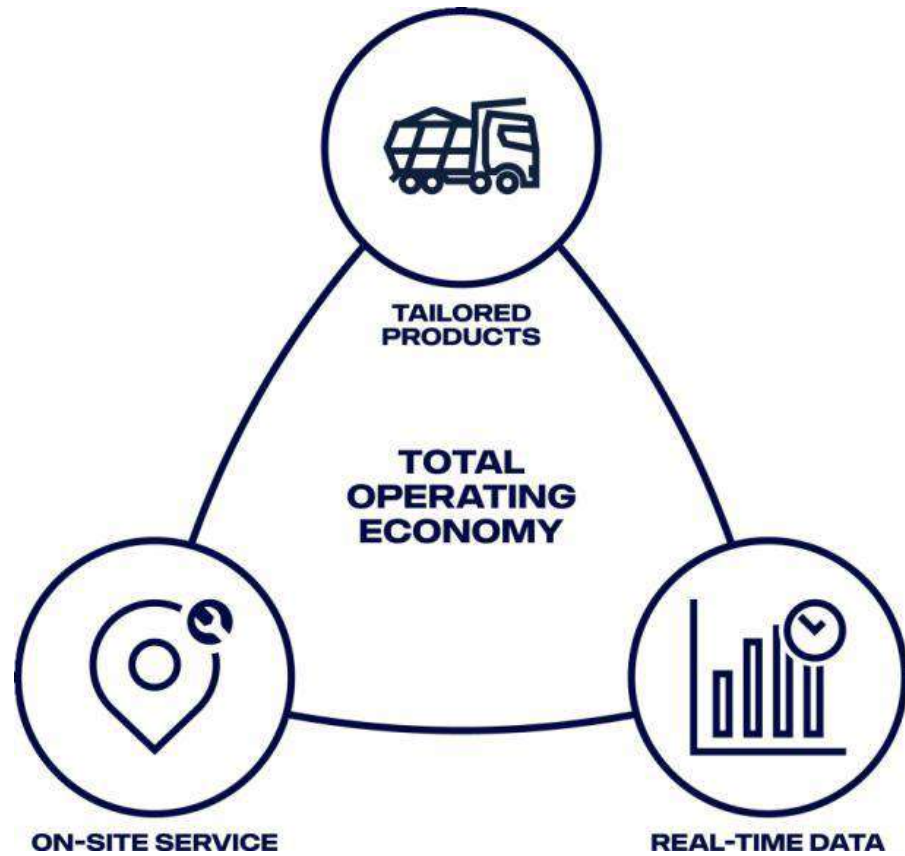



SCANIA